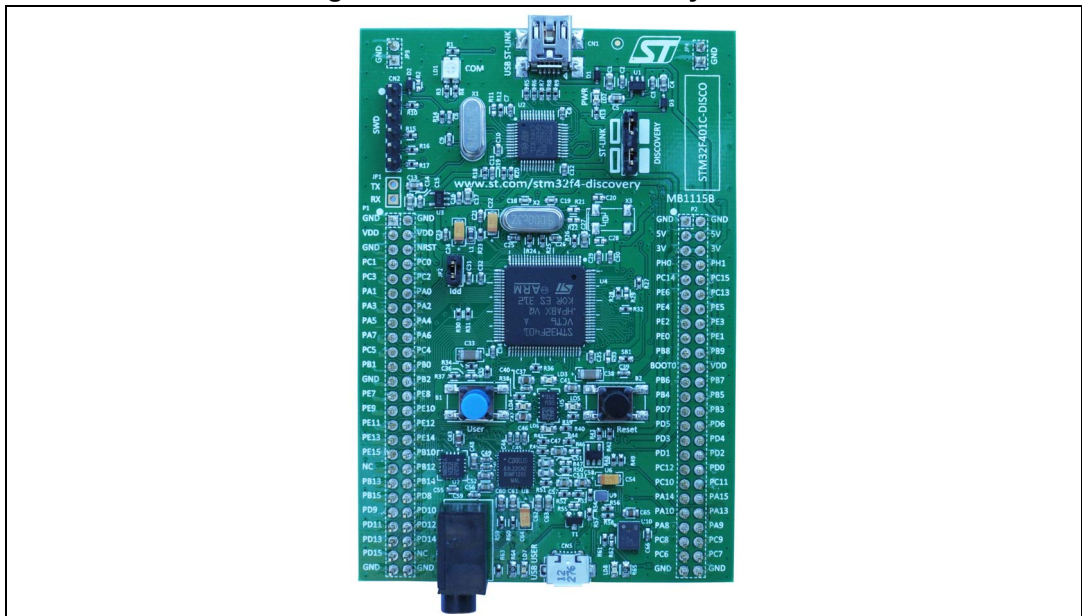


### Introduction

The STM32F401 Discovery kit (32F401CDISCOVERY) helps you to discover the entry level of the STM32F4 series and to develop your applications. It is based on an STM32F401VCT6 and includes an ST-LINK/V2 embedded debug tool interface, ST MEMS Gyroscope, ST MEMS accelerometer + magnetometer, ST MEMS digital microphone, audio DAC with integrated class D speaker driver, LEDs, pushbuttons and a USB OTG micro-AB connector.

Figure 1. STM32F401 Discovery board



# Contents

- 1 Conventions ..... 6**
- 2 Quick start ..... 7**
  - 2.1 Getting started ..... 7
  - 2.2 System requirements ..... 7
  - 2.3 Development toolchain supporting the STM32F401 Discovery kit ..... 7
  - 2.4 Order code ..... 7
- 3 Features ..... 8**
- 4 Hardware layout ..... 9**
  - 4.1 STM32F401VCT6 microcontroller ..... 12
  - 4.2 Embedded ST-LINK/V2 ..... 15
    - 4.2.1 Using ST-LINK/V2 to program/debug the STM32F401 on board ..... 16
    - 4.2.2 Using ST-LINK/V2 to program/debug an external STM32 application .. 17
  - 4.3 Power supply and power selection ..... 18
  - 4.4 LEDs ..... 18
  - 4.5 Pushbuttons ..... 18
  - 4.6 On board audio capability ..... 19
  - 4.7 USB OTG supported ..... 19
  - 4.8 E-compass MEMS (ST MEMS LSM303DLHC) ..... 19
  - 4.9 Gyroscope MEMS (ST MEMS L3GD20) ..... 19
  - 4.10 JP2 (Idd) ..... 20
  - 4.11 OSC clock ..... 20
    - 4.11.1 OSC clock supply ..... 20
    - 4.11.2 OSC 32 KHz clock supply ..... 20
  - 4.12 Solder bridges ..... 21
  - 4.13 Extension connectors ..... 22
- 5 Mechanical drawing ..... 30**
- 6 Electrical schematics ..... 31**

**7      Revision history ..... 37**

## List of tables

Table 1.	ON/OFF conventions . . . . .	6
Table 2.	Features and benefits . . . . .	12
Table 3.	Jumper states . . . . .	15
Table 4.	Debug connector CN2 (SWD) . . . . .	17
Table 5.	Solder bridges . . . . .	21
Table 6.	MCU pin description versus board function . . . . .	22
Table 7.	Document revision history . . . . .	37

## List of figures

Figure 1.	STM32F401 Discovery board	1
Figure 1.	Hardware block diagram	9
Figure 2.	Top layout	10
Figure 3.	Bottom layout	11
Figure 4.	STM32F401VCT6 microcontroller	12
Figure 5.	STM32F401VCT6 block diagram	14
Figure 6.	Typical configuration	15
Figure 7.	STM32F401 Discovery board connections image	16
Figure 8.	ST-Link connections image	17
Figure 9.	STM32F401 Discovery board mechanical drawing	30
Figure 10.	STM32F401 Discovery board	31
Figure 11.	ST-LINK/V2 (SWD only)	32
Figure 12.	STM32F401VCT6 MCU	33
Figure 13.	Audio	34
Figure 14.	USB_OTG_FS	35
Figure 15.	Peripherals	36

# 1 Conventions

*Table 1* provides the definition of some conventions used in the present document.

**Table 1. ON/OFF conventions**

<b>Convention</b>	<b>Definition</b>
Jumper JPx ON	Jumper fitted
Jumper JPx OFF	Jumper not fitted
Solder bridge SBx ON	SBx connections closed by solder
Solder bridge SBx OFF	SBx connections left open

## 2 Quick start

The STM32F401 Discovery is a low-cost and easy-to-use development kit to quickly evaluate and start a development with an STM32F4 entry level microcontroller.

Before installing and using the product, please accept the Evaluation Product License Agreement from [www.st.com/stm32f4-discovery](http://www.st.com/stm32f4-discovery).

For more information on the STM32F401 Discovery board and for demonstration software, visit [www.st.com/stm32f4-discovery](http://www.st.com/stm32f4-discovery).

### 2.1 Getting started

Follow the sequence below to configure the STM32F401 Discovery board and launch the DISCOVER application:

1. Ensure that the jumpers JP2 and CN3 are set to "on" (Discovery mode).
2. Connect the STM32F401 Discovery board to a PC using a USB cable type A/mini-B through the USB ST-LINK connector CN1, to power the board. The LED LD2 (PWR) will light up and the four LEDs between the buttons B1 and B2 start blinking.
3. Press the user button B1 to enable the MEMS sensor. The four LEDs will indicate the board motion direction and speed. When connected to a PC with a second USB type A/micro-B cable through CN5, the board will be recognized as a standard mouse.
4. The demo software, as well as other software examples that allow you to discover the STM32 F4 series features, are available on [www.st.com/stm32f4-discovery](http://www.st.com/stm32f4-discovery).
5. Develop your own applications starting from the examples.

### 2.2 System requirements

- Windows PC (XP, Vista, 7)
- USB type A to mini-B cable

### 2.3 Development toolchain supporting the STM32F401 Discovery kit

- Altium: TASKING™ VX-Toolset
- Atollic: TrueSTUDIO
- IAR: EWARM
- Keil™: MDK-ARM

### 2.4 Order code

To order the STM32F401 Discovery kit, use the STM32F401C-DISCO order code.

### 3 Features

The STM32F401 Discovery board offers the following features:

- STM32F401VCT6 microcontroller featuring 256 KB of Flash memory, 64 KB of RAM in an LQFP100 package
- On-board ST-LINK/V2 with selection mode switch to use the kit as a standalone ST-LINK/V2 (with SWD connector for programming and debugging)
- Board power supply: through USB bus or from an external 5 V supply voltage
- External application power supply: 3 V and 5 V
- L3GD20, ST MEMS motion sensor, 3-axis digital output gyroscope.
- LSM303DLHC, ST MEMS system-in-package featuring a 3D digital linear acceleration sensor and a 3D digital magnetic sensor.
- MP45DT02, ST MEMS audio sensor, omnidirectional digital microphone
- CS43L22, audio DAC with integrated class D speaker driver
- Eight LEDs:
  - LD1 (red/green) for USB communication
  - LD2 (red) for 3.3 V power on
  - Four user LEDs:  
LD3 (orange), LD4 (green), LD5 (red) and LD6 (blue)
  - Two USB OTG LEDs:  
LD7 (green) VBus and LD8 (red) over-current
- Two pushbuttons (user and reset)
- USB OTG with micro-AB connector
- Extension header for LQFP100 I/Os for a quick connection to the prototyping board and an easy probing



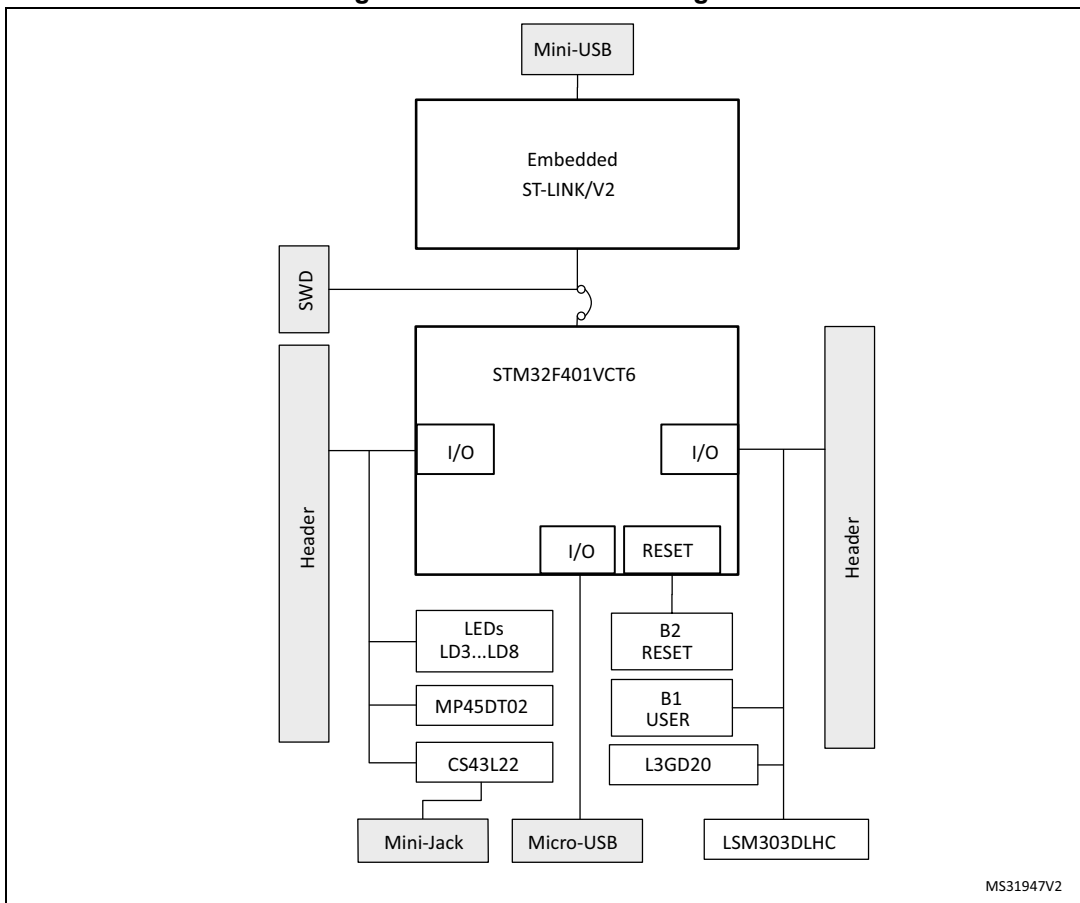
## 4 Hardware layout

The STM32F401 Discovery board has been designed around the STM32F401VCT6 microcontroller in a 100-pin LQFP package.

*Figure 1* illustrates the connections between the STM32F401VCT6 and its peripherals (ST-LINK/V2, pushbutton, LED, Audio DAC, USB, ST MEMS gyroscope, ST MEMS accelerometer + magnetometer, ST MEMS microphone, and connectors).

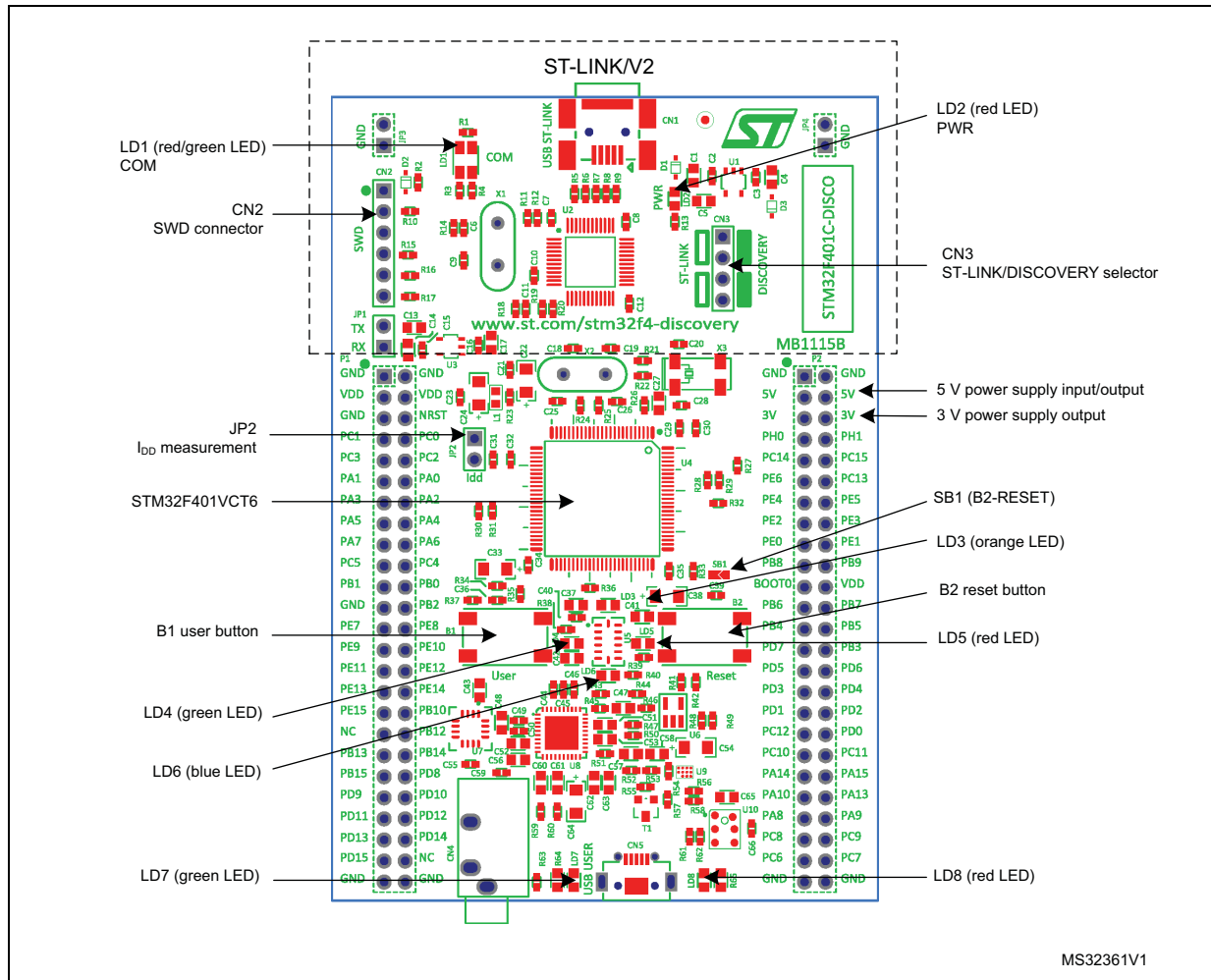
*Figure 2* and *Figure 3* help you to locate these features on the STM32F401 Discovery board.

**Figure 1. Hardware block diagram**



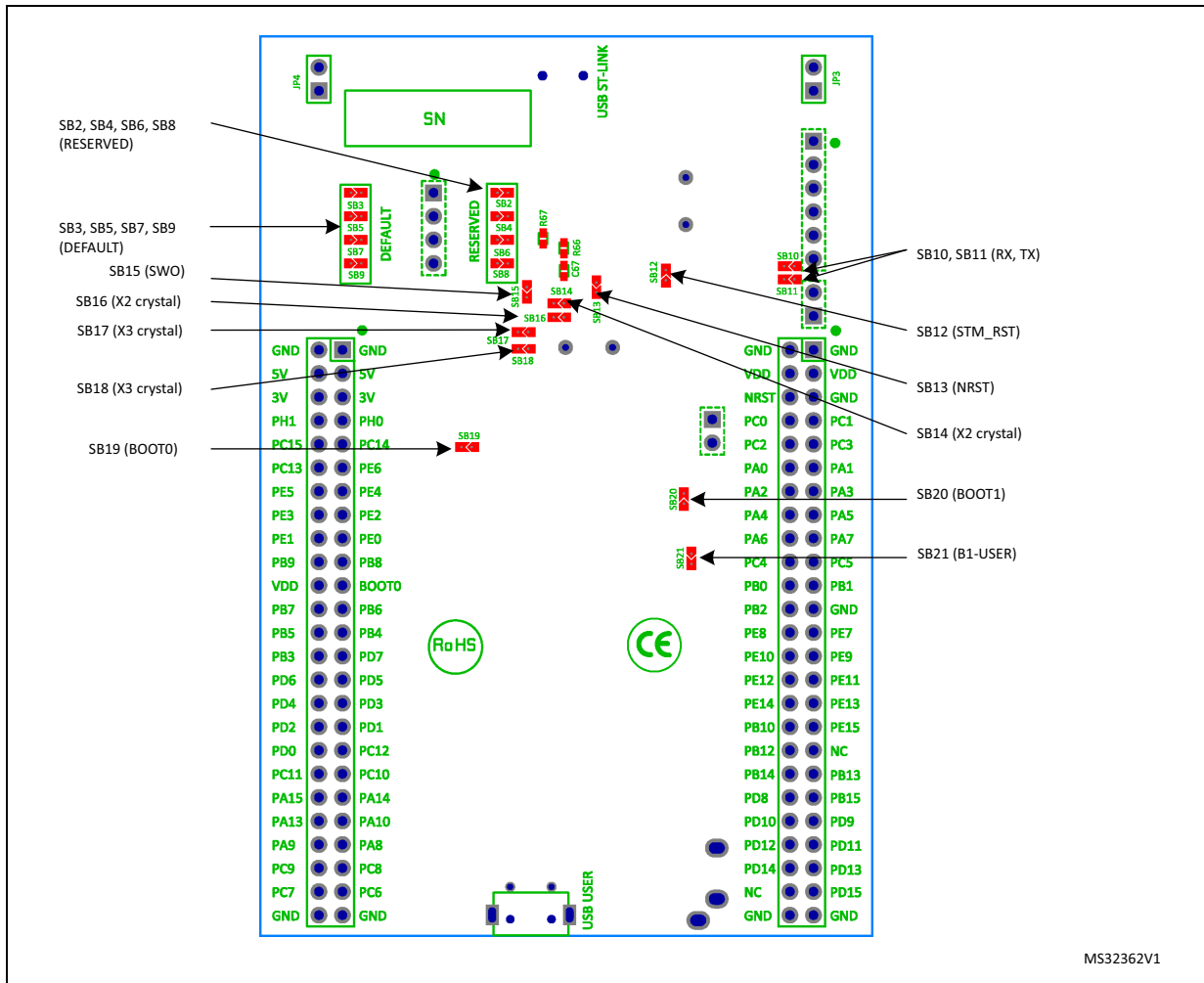
MS31947V2

Figure 2. Top layout



MS32361V1

Figure 3. Bottom layout

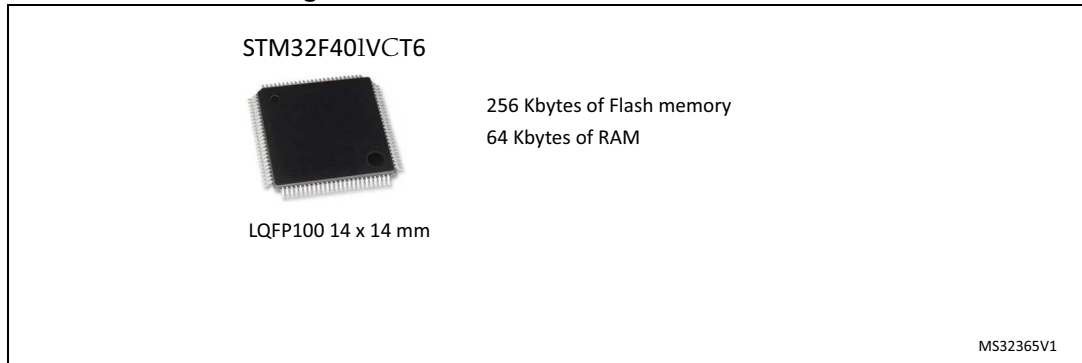


MS32362V1

## 4.1 STM32F401VCT6 microcontroller

This ARM Cortex-M4 32-bit MCU with FPU has 105 DMIPS, up to 256 KB Flash/64 KB RAM, USB OTG FS, 10 TIMs, 1 ADC, 11 comm. interfaces.

**Figure 4. STM32F401VCT6 microcontroller**



This device provides the following benefits (see [Table 2](#)).

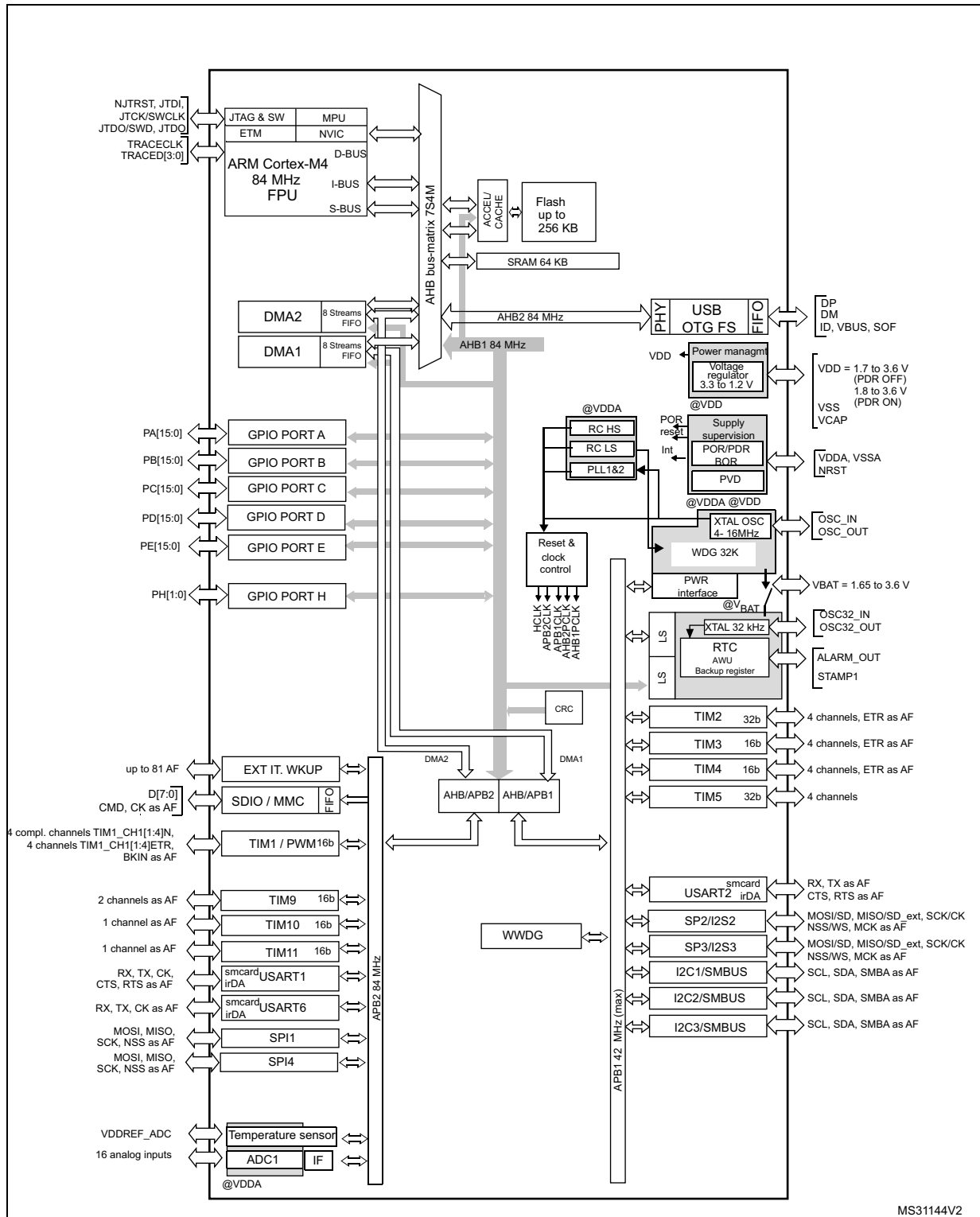
**Table 2. Features and benefits**

Features	Benefits
<p><b>High performance</b></p> <ul style="list-style-type: none"> <li>– Up to 84 MHz/105 DMIPS Cortex-M4 with single cycle DSP MAC and floating point unit</li> <li>– CoreMark: 285 at 84 MHz</li> <li>– CoreMark/MHz:3.39</li> </ul>	<ul style="list-style-type: none"> <li>– Boosted execution of control algorithms</li> <li>– More features for your applications</li> <li>– Ease of use</li> <li>– Better code efficiency</li> <li>– Faster time to market</li> <li>– Elimination of scaling and saturation</li> <li>– Easier support for meta-language tools</li> </ul>
<p><b>Maximum integration</b></p> <ul style="list-style-type: none"> <li>– Up to 256 kB of on-chip Flash, 64k B of SRAM, reset circuit, internal RCs, PLLs, ultra-small packages (WLCSP)</li> </ul>	<p>More features in space-constrained applications</p>
<p><b>Designed for high performance and ultra-fast data transfers</b></p> <ul style="list-style-type: none"> <li>– ART Accelerator™: memory accelerator</li> </ul>	<p>Performance equivalent to zero-wait execution from Flash</p>
<ul style="list-style-type: none"> <li>– 32-bit 7-layer bus matrix with 6 masters and 5 slaves including 1 block of SRAM</li> <li>– Multi DMA controllers: 2 general-purpose</li> </ul>	<p>Concurrent execution and data transfer</p>
<p><b>Outstanding power efficiency</b></p> <ul style="list-style-type: none"> <li>– Ultra-low dynamic power in Run mode: 140 µA/MHz at 84 MHz running CoreMark benchmark from Flash memory (peripherals off)</li> <li>– RTC &lt;1 µA typ in V<sub>BAT</sub> mode</li> <li>– Down to 11 µA typ in Stop mode</li> <li>– 3.6 V down to 1.7 V V<sub>DD</sub></li> <li>– 1.2 V voltage regulator with power scaling capability</li> </ul>	<p>Extra flexibility to reduce power consumption for applications requiring both high-processing and low-power performance when running at low voltage or on a rechargeable battery</p>

Table 2. Features and benefits (continued)

Features	Benefits
<b>Superior and innovative peripherals and connectivity</b> <ul style="list-style-type: none"> <li>– 1x USB OTG</li> <li>– Up to 11 communication interfaces (including 3x USART, 4x SPI, 3x I<sup>2</sup>C with digital filter, 1 SDIO)</li> <li>– USART at up to 10.5 Mbit/s</li> <li>– SPI at up to 42 Mbit/s</li> </ul>	New possibilities to connect and communicate high-speed data
<b>Audio:</b> <ul style="list-style-type: none"> <li>– dedicated audio PLL, 2x I<sup>2</sup>S</li> </ul>	High-quality audio support
<b>Analog:</b> <ul style="list-style-type: none"> <li>– 1 x 12-bit ADC reaching 2.4 MSPS</li> <li>– Up to 10 timers: 16 and 32 bits running up to 84 MHz</li> </ul>	More precision thanks to high resolution
<b>High integration</b> <ul style="list-style-type: none"> <li>– WLCSP49 3 x 3 mm (STM32F401, 256-Kbyte Flash/ 64-Kbyte SRAM)</li> </ul>	Smaller board space allowing for smaller applications
<b>Extensive tools and software solutions</b> <ul style="list-style-type: none"> <li>– Hardware sector protection with execute only access</li> <li>– Various IDE, starter kits, libraries, RTOS and stacks, either open source or provided by ST or 3rd parties, including the ARM CMSIS DSP library optimized for Cortex-M4 instructions</li> </ul>	<ul style="list-style-type: none"> <li>– Software IP protection</li> <li>– A wide choice within the STM32 ecosystem to develop your applications</li> </ul>

Figure 5. STM32F401VCT6 block diagram



MS31144V2

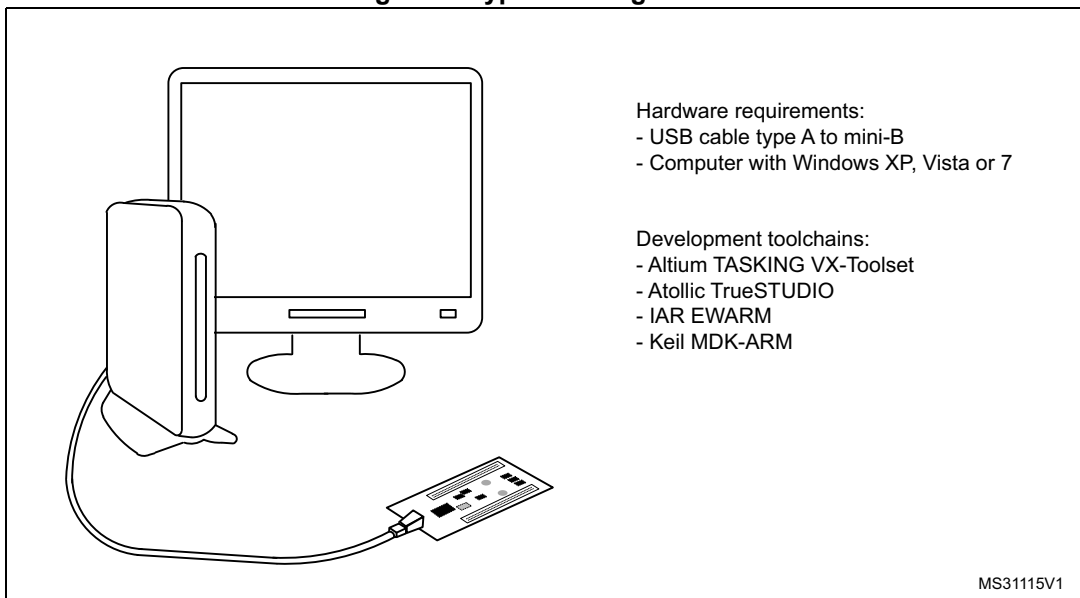
## 4.2 Embedded ST-LINK/V2

The ST-LINK/V2 programming and debugging tool is integrated on the STM32F401 Discovery board. The embedded ST-LINK/V2 can be used in 2 different ways according to the jumper states (see [Table 3](#)):

- Program/debug the MCU on board,
- Program/debug an MCU in an external application board using a cable connected to SWD connector CN2.

The embedded ST-LINK/V2 supports only SWD for STM32 devices. For information about debugging and programming features, refer to user manual UM1075 (ST-LINK/V2 in-circuit debugger/programmer for STM8 and STM32) which describes in detail all the ST-LINK/V2 features.

**Figure 6. Typical configuration**



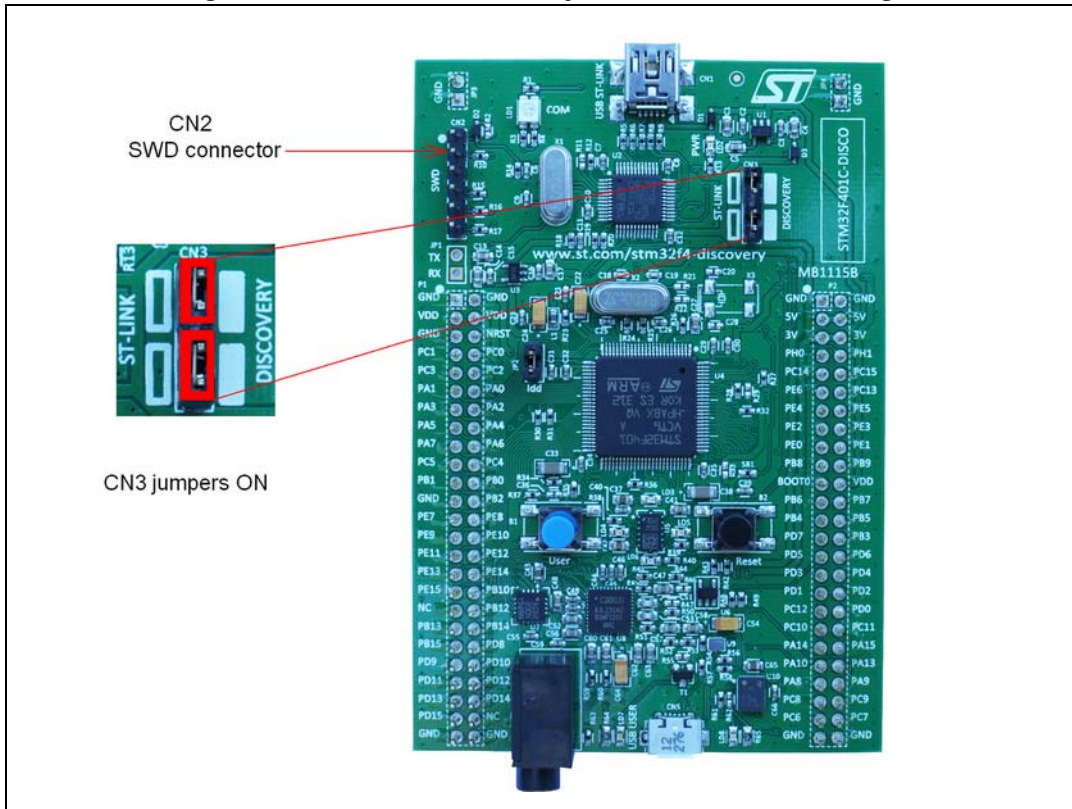
**Table 3. Jumper states**

Jumper state	Description
Both CN3 jumpers ON	ST-LINK/V2 functions enabled for on board programming (default)
Both CN3 jumpers OFF	ST-LINK/V2 functions enabled for application through external CN2 connector (SWD supported)

### 4.2.1 Using ST-LINK/V2 to program/debug the STM32F401 on board

To program the STM32F401 on board, simply plug in the two jumpers on CN3, as shown in [Figure 7](#) in red, but do not use the CN2 connector as that could disturb communication with the STM32F401VCT6 of the STM32F401 Discovery board.

Figure 7. STM32F401 Discovery board connections image





### 4.2.2 Using ST-LINK/V2 to program/debug an external STM32 application

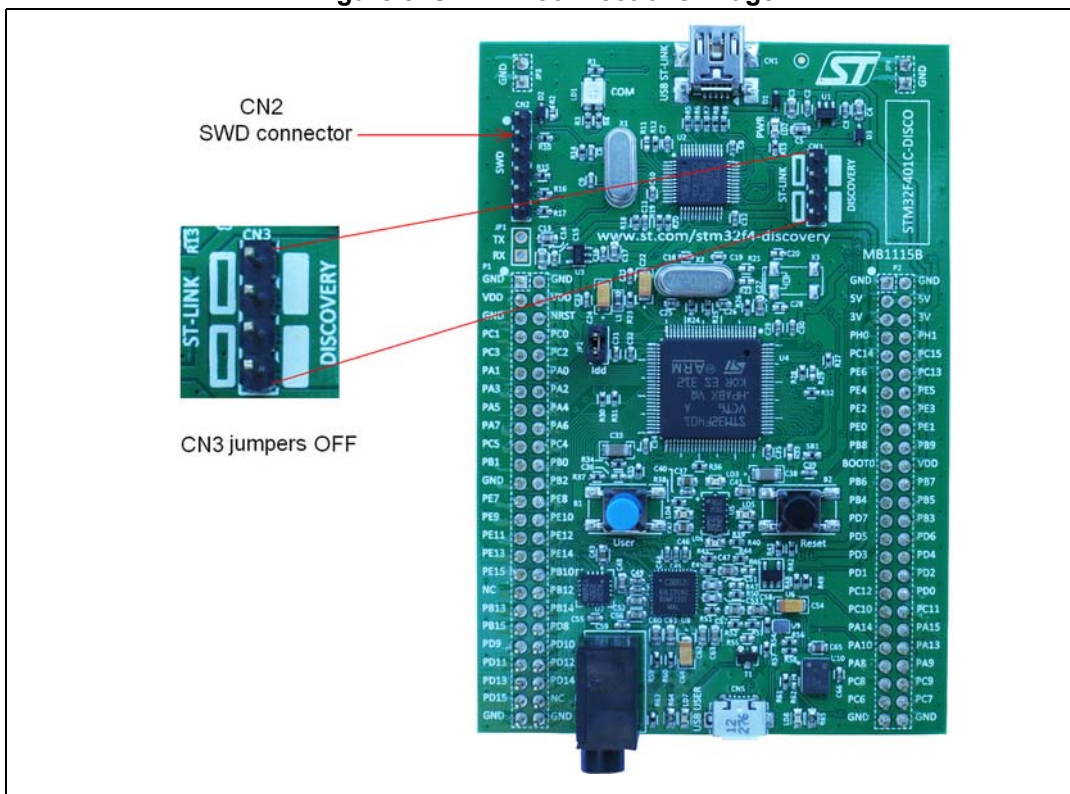
It is very easy to use the ST-LINK/V2 to program the STM32 on an external application. Simply remove the 2 jumpers from CN3 as shown in [Figure 8](#), and connect your application to the CN2 debug connector according to [Table 4](#).

*Note:* SB13 must be OFF if you use CN2 pin 5 in your external application.

**Table 4. Debug connector CN2 (SWD)**

Pin	CN2	Designation
1	VDD_TARGET	VDD from application
2	SWCLK	SWD clock
3	GND	Ground
4	SWDIO	SWD data input/output
5	NRST	RESET of target MCU
6	SWO	Reserved

**Figure 8. ST-Link connections image**



### 4.3 Power supply and power selection

The power supply is provided either by the host PC through the USB cable, or by an external 5 V power supply.

The D1 and D2 diodes protect the 5 V and 3 V pins from external power supplies:

- 5 V and 3 V can be used as output power supplies when another application board is connected to pins P1 and P2.  
In this case, the 5 V and 3 V pins deliver a 5 V or 3 V power supply and the power consumption must be lower than 100 mA.
- 5 V can also be used as input power supplies, e.g. when the USB connector is not connected to the PC.  
In this case, the STM32F401 Discovery board must be powered by a power supply unit or by an auxiliary equipment complying with standard EN-60950-1: 2006+A11/2009, and must be Safety Extra Low Voltage (SELV) with limited power capability.

### 4.4 LEDs

- LD1 COM:  
LD1 default status is red. LD1 turns to green to indicate that communications are in progress between the PC and the ST-LINK/V2.
- LD2 PWR:  
The red LED indicates that the board is powered.
- User LD3:  
The orange LED is a user LED connected to the I/O PD13 of the STM32F401VCT6.
- User LD4:  
The green LED is a user LED connected to the I/O PD12 of the STM32F401VCT6.
- User LD5:  
The red LED is a user LED connected to the I/O PD14 of the STM32F401VCT6.
- User LD6:  
The blue LED is a user LED connected to the I/O PD15 of the STM32F401VCT6.
- USB LD7:  
The green LED indicates when VBUS is present on CN5 and is connected to PA9 of the STM32F401VCT6.
- USB LD8:  
The red LED indicates an overcurrent from VBUS of CN5 and is connected to the I/O PD5 of the STM32F401VCT6.

### 4.5 Pushbuttons

- B1 USER:  
User and Wake-Up button connected to the I/O PA0 of the STM32F401VCT6.
- B2 RESET:  
The pushbutton connected to NRST is used to RESET the STM32F401VCT6.

## 4.6 On board audio capability

The STM32F401 uses an audio DAC (CS43L22) to output sounds through the audio mini jack connector.

The STM32F401 controls the audio DAC through the I2C interface and processes digital signals through an I2S connection or analog input signal.

- The sound can come independently from different inputs:
  - ST MEMS microphone (MP45DT02): digital using PDM protocol or analog when using the low pass filter.
  - USB connector: from external mass storage such as a USB key, USB HDD, and so on.
  - Internal memory of the STM32F401.
- The sound can be output in different ways through audio DAC:
  - Using the I2S protocol
  - Using the microphone output directly via a low pass filter to analog input AIN4x of the CS43L22

## 4.7 USB OTG supported

The STM32F401 is used to drive only USB OTG full speed on this board. The USB micro-AB connector (CN5) allows the user to connect a host or device component, such as a USB key, mouse, and so on.

Two LEDs are dedicated to this module:

- LD7 (green LED) indicates when VBUS is active
- LD8 (red LED) indicates an overcurrent from a connected device.

## 4.8 E-compass MEMS (ST MEMS LSM303DLHC)

The LSM303DLHC is an ultra-compact low-power system-in-package featuring a 3D digital linear acceleration sensor and a 3D digital magnetic sensor. It includes a sensing element and an IC interface able to provide the measured acceleration to the external world through an I2C serial interface.

The LSM303DLHC has dynamically user-selectable full scales of  $\pm 2g/\pm 8g$  and is capable of measuring the acceleration, and a magnetic field full scale from  $\pm 1.3 g$  to  $8.1 g$  with an output data rate of 100 Hz or 400 Hz.

The STM32F401VCT6 MCU controls this motion sensor through the I2C interface.

## 4.9 Gyroscope MEMS (ST MEMS L3GD20)

The L3GD20 is an ultra-compact, low-power, three-axis angular rate sensor. It includes a sensing element and an IC interface able to provide the measured angular rate to the external world through the I2C/SPI serial interface.

The L3GD20 has dynamically user-selectable full scales of  $\pm 250 \text{ dps}/500 \text{ dps}/\pm 2000 \text{ dps}$  and is capable of measuring rates.

The STM32F401VCT6 MCU controls this motion sensor through the SPI interface.

## 4.10 JP2 (Idd)

Jumper JP2, labeled Idd, allows the consumption of STM32F401VCT6 to be measured by removing the jumper and connecting an ammeter.

- Jumper on: STM32F401VCT6 is powered (default).
- Jumper off: an ammeter must be connected to measure the STM32F401VCT6 current, (if there is no ammeter, the STM32F401VCT6 is not powered).

## 4.11 OSC clock

### 4.11.1 OSC clock supply

If PH0 and PH1 are only used as GPIOs instead of as a clock, then SB14 and SB16 are closed and R24, R25 and R66 are removed.

**MCO from ST-LINK** (from MCO of the STM32F103)

This frequency cannot be changed, it is fixed at 8 MHz and connected to PH0-OSC\_IN of the STM32F401VCT6. The configuration needed is:

- SB14, SB16 OPEN
- R25 removed
- R66 soldered

**Oscillator onboard** (from X2 crystal)

For typical frequencies and its capacitors and resistors, please refer to the STM32F401VCT6 Datasheet. The configuration needed is:

- SB14, SB16 OPEN
- R25 soldered
- R66 removed

**Oscillator from external PH0** (from external oscillator through pin 7 of the P2 connector)

The configuration needed is:

- SB14 closed
- SB16 closed
- R25 and R66 removed

### 4.11.2 OSC 32 KHz clock supply

If PC14 and PC15 are only used as GPIOs instead of as a clock, then SB17 and SB18 are closed, and R21 and R22 are removed.

**Oscillator onboard** (from X1 Crystal (not provided))

The configuration needed is:

- SB17, SB18 OPEN
- C20, C28, R21 and R22 soldered

**Oscillator from external PC14** (from external oscillator through the pin 9 of P2 connector)

The configuration needed is:

- SB17 closed
- SB18 closed
- R21 and R22 removed

## 4.12 Solder bridges

**Table 5. Solder bridges**

Bridge	State <sup>(1)</sup>	Description
SB14,16 (X2 crystal)	OFF	X2, C18, C19, R24 and R25 provide a clock. PH0, PH1 are disconnected from P2
	ON	PH0, PH1 are connected to P2 R24, R25 and R66 must not be fitted).
SB3,5,7,9 (Default)	ON	Reserved, do not modify
SB2,4,6,8 (Reserved)	OFF	Reserved, do not modify
SB17,18 (X3 crystal)	OFF	X3, C20, C28, R21 and R22 deliver a 32 KHz clock. PC14, PC15 are not connected to P2.
	ON	PC14, PC15 are only connected to P2. Remove only R21, R22
SB1 (B2-RESET)	ON	B2 pushbutton is connected to the NRST pin of the STM32F401VCT6 MCU
	OFF	B2 pushbutton is not connected to the NRST pin of the STM32F401VCT6 MCU
SB21 (B1-USER)	ON	B1 pushbutton is connected to PA0
	OFF	B1 pushbutton is not connected to PA0
SB13 (NRST)	ON	NRST signal of the CN2 connector is connected to the NRST pin of the STM32F401VCT6 MCU
	OFF	NRST signal of the CN2 connector is not connected to the NRST pin of the STM32F401VCT6 MCU
SB15 (SWO)	ON	SWO signal of the CN2 connector is connected to PB3
	OFF	SWO signal is not connected
SB10,11 (RX,TX)	OFF	Reserved, do not modify
	ON	Reserved, do not modify
SB12 (STM_RST)	OFF	No incidence on STM32F103C8T6 (ST-LINK/V2) NRST signal
	ON	STM32F103C8T6 (ST-LINK/V2) NRST signal is connected to GND
SB19 (BOOT0)	ON	BOOT0 signal of the STM32F401VCT6 MCU is held low through a 510 Ω pull-down resistor
	OFF	BOOT0 signal of the STM32F401VCT6 MCU is held high through a 10 KΩ pull-up resistor
SB20 (BOOT1)	OFF	The BOOT1 signal of the STM32F401VCT6 MCU is held high through a 10 KΩ pull-up resistor
	ON	The BOOT1 signal of the STM32F401VCT6 MCU is held low through a 510 Ω pull-down resistor

1. Default SBx state is shown in bold.

### 4.13 Extension connectors

The male headers P1 and P2 can connect the STM32F401 Discovery board to a standard prototyping/wrapping board. STM32F401VCT6 GPI/Os are available on these connectors. P1 and P2 can also be probed by an oscilloscope, logical analyzer or voltmeter.

**Table 6. MCU pin description versus board function (page 1 of 8)**

MCU pin		Board function															
Main function	Alternate functions	LQFP100	CS43L22	MP45DT02	L3GD20	LSM303DLHC	Pushbutton	LED	SWD	USB	OSC	Free I/O	Power supply	CN5	CN2	P1	P2
BOOT0		94															21
NRST		14					RESET		NRST						5	6	
PA0-WKUP	TIM2_CH1/TIM2_ETR, TIM5_CH1, USART2_CTS, ADC1_0, WKUP	23					USER									12	
PA1	TIM2_CH2, TIM5_CH2, USART2_RTS, ADC1_1	24														11	
PA2	TIM2_CH3, TIM5_CH3, TIM9_CH1, USART2_TX, ADC1_2	25														14	
PA3	TIM2_CH4, TIM5_CH4, TIM9_CH2, USART2_RX, ADC1_3	26														13	
PA4	SPI1_NSS, SPI3_NSS/I2S3_WS, USART2_CK, ADC1_4	29	LRCK/AIN1x													16	
PA5	TIM2_CH1/TIM2_ETR, SPI1_SCK, ADC1_5	30			SCL/SPC											15	
PA6	TIM1_BKIN, TIM3_CH1, SPI1_MISO, ADC1_6	31			SDO											18	



Table 6. MCU pin description versus board function (page 2 of 8)

MCU pin		Board function															
Main function	Alternate functions	LQFP100	CS43L22	MP45DT02	L3GD20	LSM303DLHC	Pushbutton	LED	SWD	USB	OSC	Free I/O	Power supply	CN5	CN2	P1	P2
PA7	TIM1_CH1N, TIM3_CH2, SPI1_MOSI, ADC1_7	32			SDA/SDI/SDO											17	
PA8	MCO_1, TIM1_CH1, I2C3_SCL, USART1_CK, USB_FS_SOF	67															43
PA9	TIM1_CH2, I2C3_SMBAL, USART1_TX, USB_FS_VBUS	68						GREEN		VBUS				1			44
PA10	TIM1_CH3, USART1_RX, USB_FS_ID	69								ID				4			41
PA11	TIM1_CH4, USART1_CTS, USART6_TX, USB_FS_DM	70								DM				2			
PA12	TIM1_ETR, USART1_RTS, USART6_RX, USB_FS_DP	71								DP				3			
PA13	JTMS-SWDIO	72							SWDIO						4		42
PA14	JTCK-SWCLK, I2S3ext_WS	76							SWCLK						2		39
PA15	JTDI, TIM2_CH1/TIM2_ETR, SPI1_NSS, SPI3_NSS/I2S3_WS	77															40
PB0	TIM1_CH2N, TIM3_CH3, ADC1_8	35														22	

Table 6. MCU pin description versus board function (page 3 of 8)

MCU pin		Board function															
Main function	Alternate functions	LQFP100	CS43L22	MP45DT02	L3GD20	LSM303DLHC	Pushbutton	LED	SWD	USB	OSC	Free I/O	Power supply	CN5	CN2	P1	P2
PB1	TIM1_CH3N, TIM3_CH4, ADC1_9	36														21	
PB2		37														24	
PB3	JTDO-SWO, TIM2_CH2, SPI1_SCK, SPI3_SCK/I2S3_CK, I2C2_SDA	89							SWO						6		28
PB4	JTRST, TIM3_CH1, SPI1_MISO, SPI3_MISO, I2S3ext_SD, I2C3_SDA	90															25
PB5	TIM3_CH2, I2C1_SMBAL, SPI1_MOSI, SPI3_MOSI/I2S3_SD	91															26
PB6	TIM4_CH1, I2C1_SCL, USART1_TX, USB_FS_INT	92	SCL			SCL											23
PB7	TIM4_CH2, I2C1_SDA, USART1_RX	93															24
PB8	TIM4_CH3, TIM10_CH1, I2C1_SCL, USB_FS_SCL, SDIO_D4	95															19
PB9	TIM4_CH4, TIM11_CH1, I2C1_SDA, SPI2_NSS/I2S2_WS, USB_FS_SDA, SDIO_D5	96	SDA			SDA											20
PB10	TIM2_CH3, I2C2_SCL, SPI2_SCK/I2S2_CK	47		CLK												34	
VCAP1		48											VDD			35	





Table 6. MCU pin description versus board function (page 4 of 8)

MCU pin		Board function															
Main function	Alternate functions	LQFP100	CS43L22	MP45DT02	L3GD20	LSM303DLHC	Pushbutton	LED	SWD	USB	OSC	Free I/O	Power supply	CN5	CN2	P1	P2
PB12	TIM1_BKIN, I2C2_SMBAL, SPI2_NSS/I2S2_WS, I2S2ext_WS	51														36	
PB13	TIM1_CH1N, SPI2_SCK/I2S2_CK, I2S2ext_CK	52														37	
PB14	TIM1_CH2N, SPI2_MISO, I2S2ext_SD	53														38	
PB15	RTC_50Hz, TIM1_CH3N, SPI2_MOSI/I2S2_SD, I2S2ext_MISO	54														39	
PC0	ADC1_10	15								PowerOn						8	
PC1	ADC1_11	16														7	
PC2	SPI2_MISO, I2S2ext_SD, ADC1_12	17														10	
PC3	SPI2_MOSI/I2S2_SD, ADC1_13	18	AIN4x	PDM_OUT												9	
PC4	ADC1_14	33														20	
PC5	ADC1_15	34														19	
PC6	TIM3_CH1, I2S2_MCK, USART6_TX, SDIO_D6	63															47
PC7	TIM3_CH2, I2S3_MCK, USART6_RX, SDIO_D7	64	MCLK														48
PC8	MCO_CPUCK, TIM3_CH3, USART6_CK, SDIO_D0	65															45

Table 6. MCU pin description versus board function (page 5 of 8)

MCU pin		Board function															
Main function	Alternate functions	LQFP100	CS43L22	MP45DT02	L3GD20	LSM303DLHC	Pushbutton	LED	SWD	USB	OSC	Free I/O	Power supply	CN5	CN2	P1	P2
PC9	MCO_2, TIM3_CH4, I2C3_SDA, I2S2_CKIN, SDIO_D1	66															46
PC10	I2S3ext_CK, SPI3_SCK/I2S3_CK, SDIO_D2	78	SCLK														37
PC11	I2S3ext_SD, SPI3_MISO, SDIO_D3	79															38
PC12	I2S3ext_MISO, SPI3_MOSI/I2S3_SD, SDIO_CK	80	SDIN														35
PC13	TAMP_1	7															12
PC14	OSC32_IN	8									OSC32_IN						9
PC15	OSC32_OUT	9									OSC32_OUT						10
PD0		81															36
PD1		82															33
PD2	TIM3_ETR, SDIO_CMD	83															34
PD3	SPI2_SCK/I2S2_CK, USART2_CTS	84															31
PD4	USART2_RTS	85	RESET														32
PD5	USART2_TX	86						RED		OverCurrent							29
PD6	SPI3_MOSI/I2S3_SD, USART2_RX	87															30



Table 6. MCU pin description versus board function (page 6 of 8)

MCU pin			Board function														
Main function	Alternate functions	LQFP100	CS43L22	MP45DT02	L3GD20	LSM303DLHC	Pushbutton	LED	SWD	USB	OSC	Free I/O	Power supply	CN5	CN2	P1	P2
PD7	USART2_CK	88															27
PD8		55															40
PD9		56															41
PD10		57															42
PD11		58															43
PD12	TIM4_CH1	59						GREEN									44
PD13	TIM4_CH2	60						ORANGE									45
PD14	TIM4_CH3	61						RED									46
PD15	TIM4_CH4	62						BLUE									47
PE0	TIM4_ETR	97			INT1												17
PE1		98			INT2												18
PE2	TRACECLK, SPI4_SCK	1				DRDY											15
PE3	TRACED0	2			CS_I2C/SPI												16
PE4	TRACED1, SPI4_NSS	3				INT1											13
PE5	TRACED2, TIM9_CH1, SPI4_MISO	4				INT2											14
PE6	TRACED3, TIM9_CH2, SPI4_MOSI	5															11
PE7	TIM1_ETR	38															25

Table 6. MCU pin description versus board function (page 7 of 8)

MCU pin			Board function														
Main function	Alternate functions	LQFP100	CS43L22	MP45DT02	L3GD20	LSM303DLHC	Pushbutton	LED	SWD	USB	OSC	Free I/O	Power supply	CN5	CN2	P1	P2
PE8	TIM1_CH1N	39														26	
PE9	TIM1_CH1	40														27	
PE10	TIM1_CH2N	41														28	
PE11	TIM1_CH2, SPI4_NSS	42														29	
PE12	TIM1_CH3N, SPI4_SCK	43														30	
PE13	TIM1_CH3, SPI4_MISO	44														31	
PE14	TIM1_CH4, SPI4_MOSI	45														32	
PE15	TIM1_BKIN	46														33	
PH0	OSC_IN	12									OSC_IN						7
PH1	OSC_OUT	13									OSC_OUT						8
													5 V				3
													5 V				4
													3 V				5
													3 V				6
													VDD			3	22
													VDD			4	
									GND	GND			GND	5	3	1	1
													GND			2	2
													GND			5	
													GND			23	

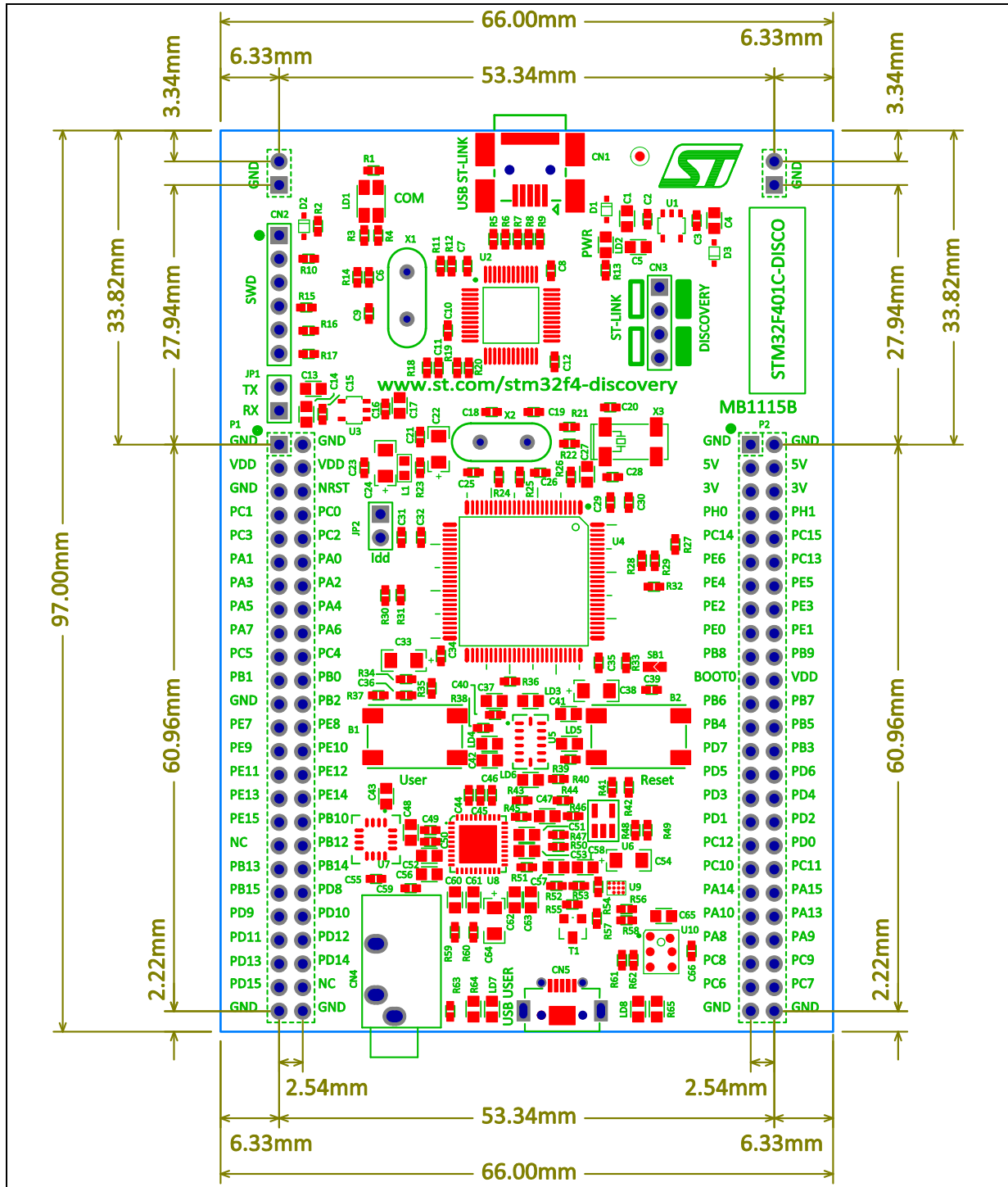


Table 6. MCU pin description versus board function (page 8 of 8)

MCU pin		Board function															
Main function	Alternate functions	LQFP100	CS43L22	MP45DT02	L3GD20	LSM303DLHC	Pushbutton	LED	SWD	USB	OSC	Free I/O	Power supply	CN5	CN2	P1	P2
													GND			49	49
													GND			50	50

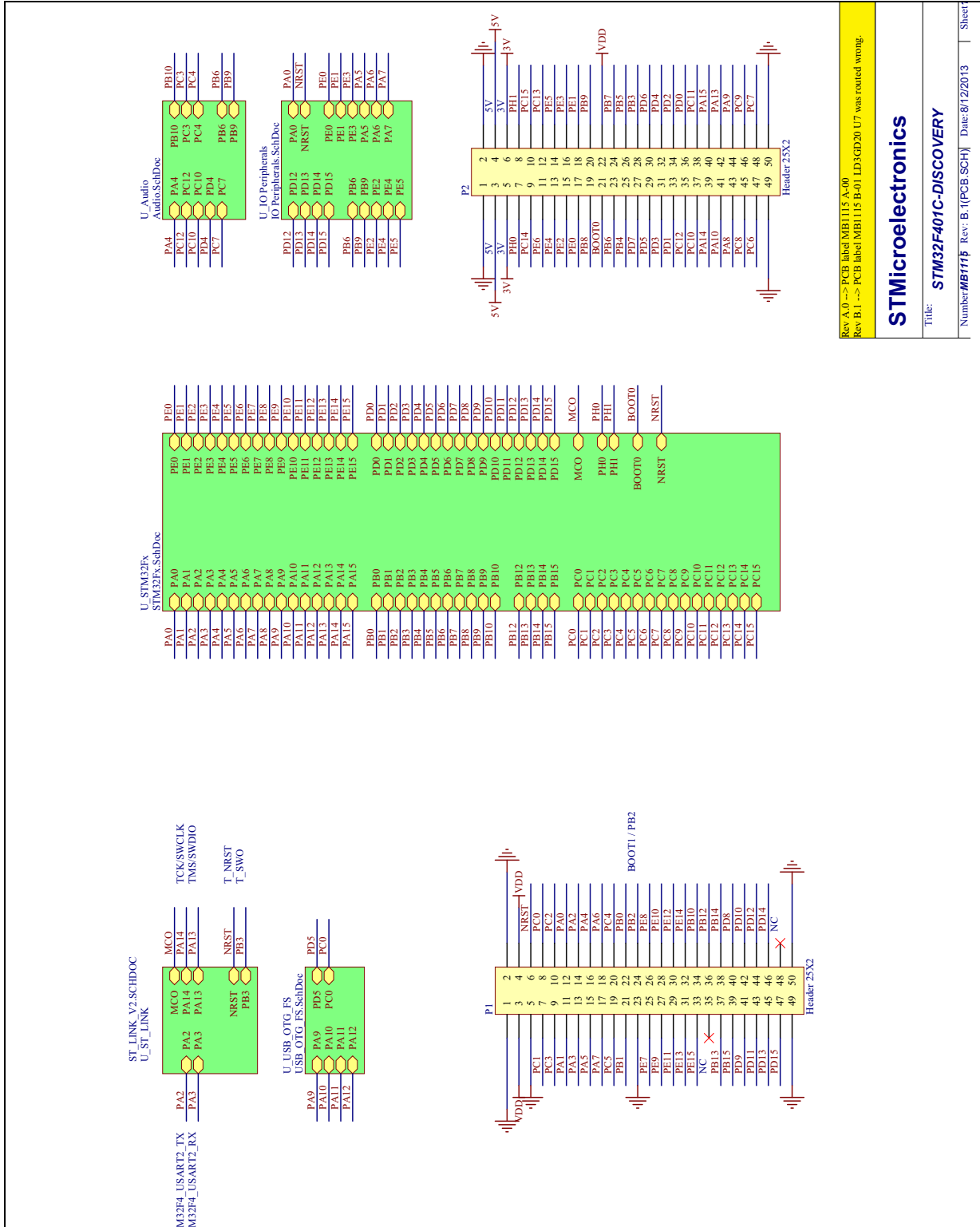
# 5 Mechanical drawing

Figure 9. STM32F401 Discovery board mechanical drawing



# 6 Electrical schematics

Figure 10. STM32F401 Discovery board



Rev A.0 -> PCB label MBI115 A-00  
 Rev B.1 -> PCB label MBI115 B-01 LD3GD20 U7 was routed wrong.

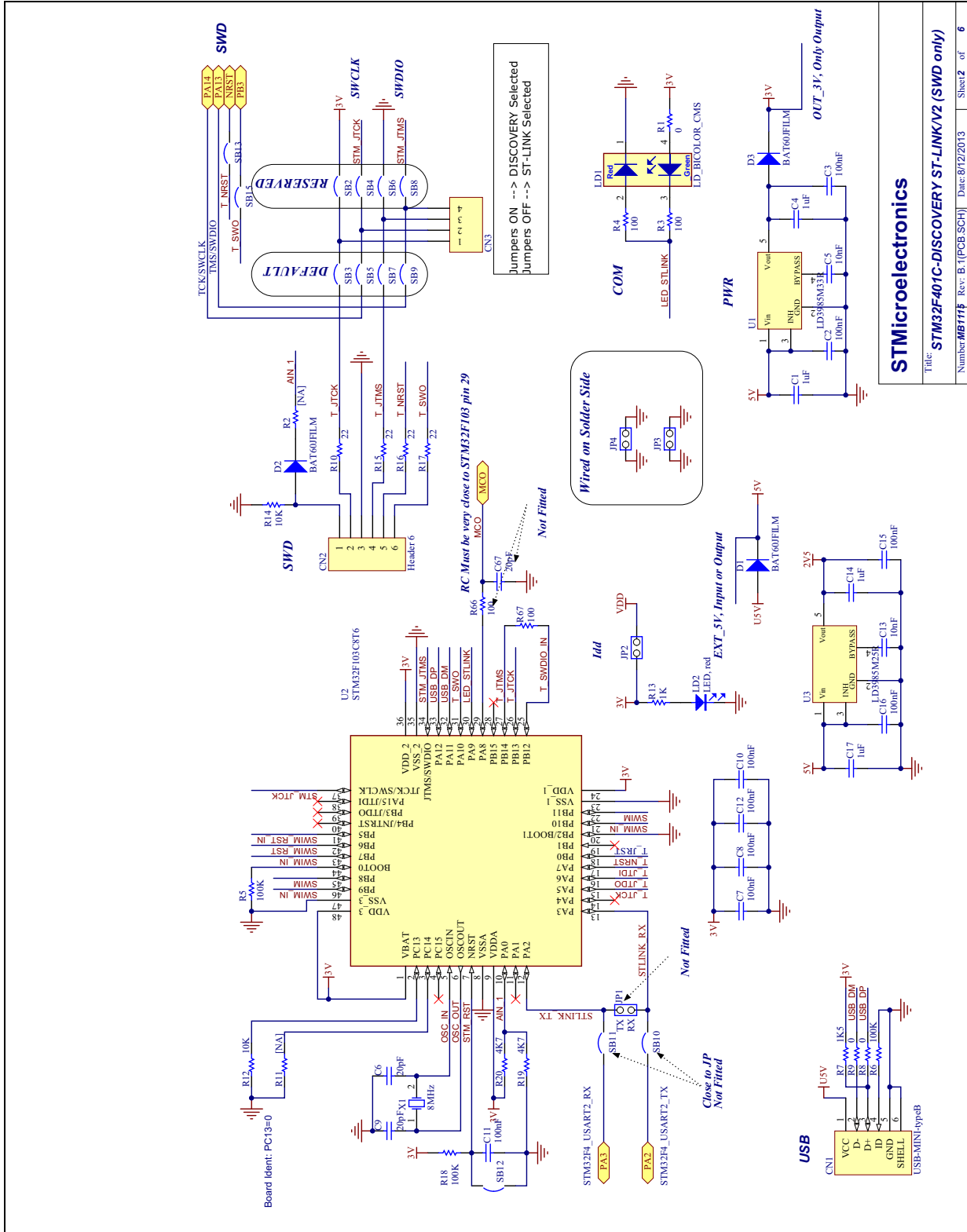
**STMicroelectronics**

Title: **STM32F401C-DISCOVERY**

Number: **MB1115** Rev: B.1 (PCB.SCH) Date: 8/12/2013 Sheet



Figure 11. ST-LINK/V2 (SWD only)

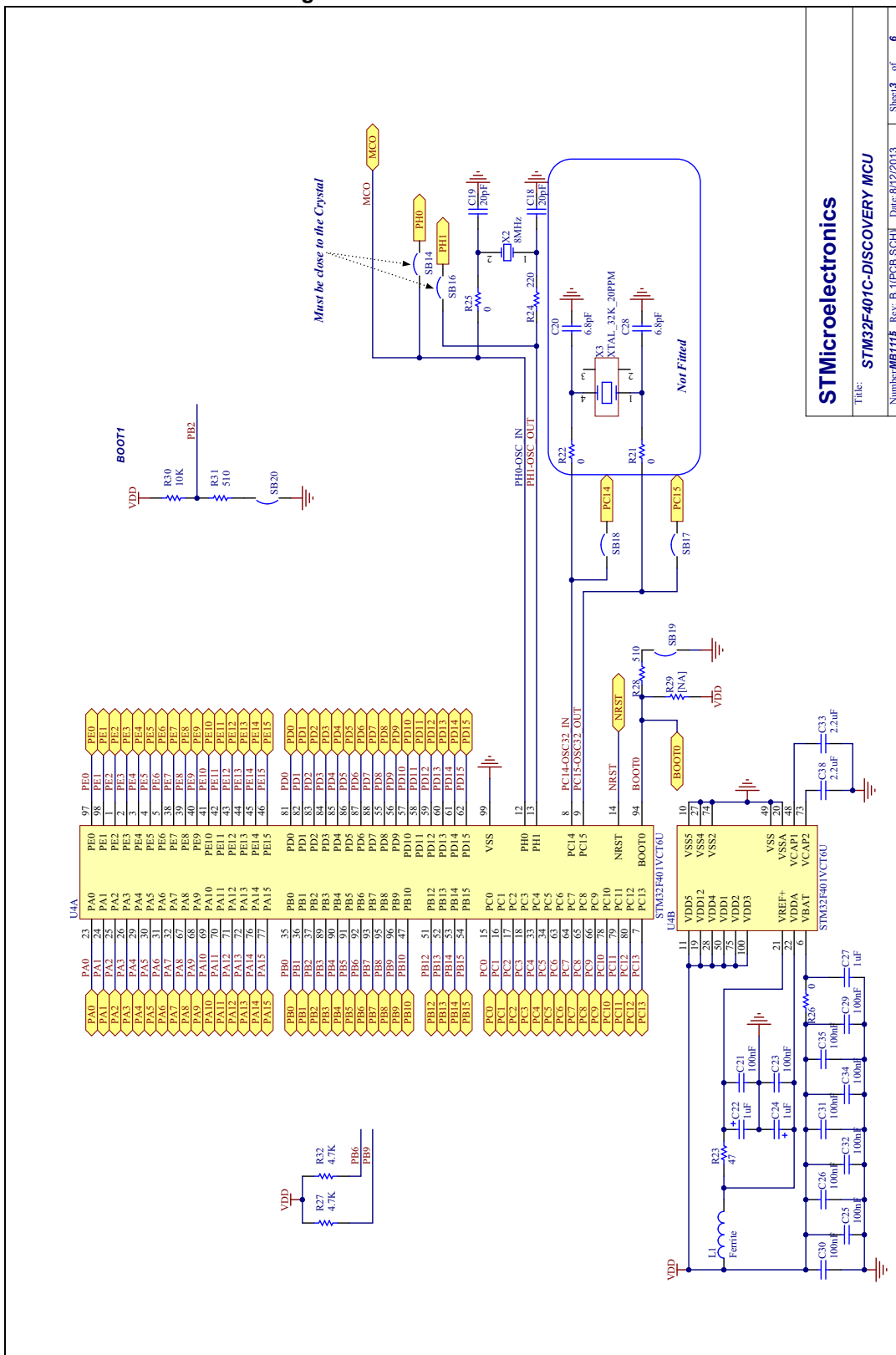


<b>STMicroelectronics</b>	
Title: <b>STM32F401C-DISCOVERY ST-LINK/V2 (SWD only)</b>	
Number: <b>UM1669</b>	Rev: <b>B.1 (PCB SCH)</b>
Date: <b>01/22/2013</b>	Sheet <b>2</b> of <b>6</b>





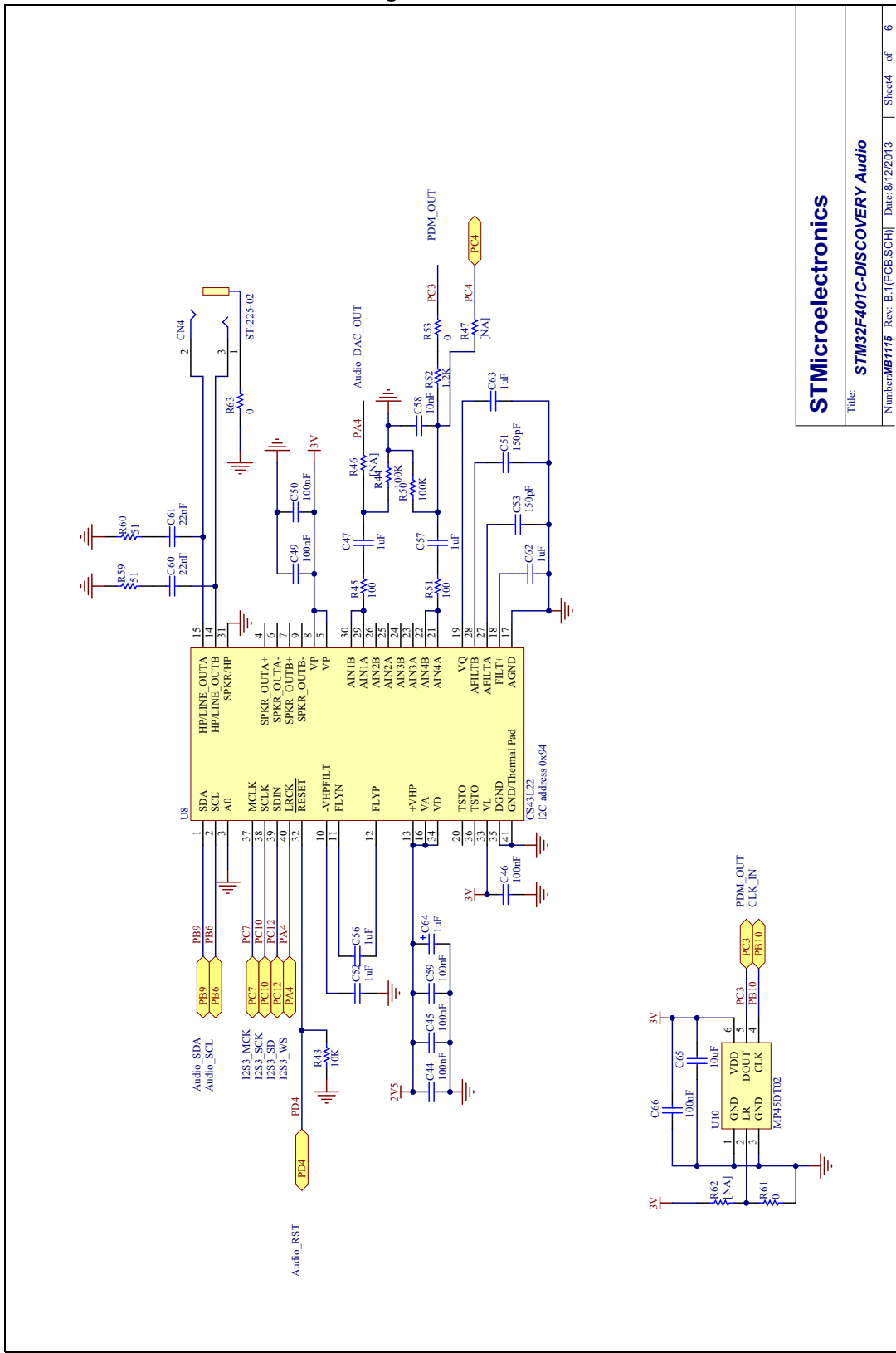
Figure 12. STM32F401VCT6 MCU



**STMicroelectronics**  
 Title: **STM32F401C-DISCOVERY MCU**  
 Number: **UM1111** Rev: **B.1** [PCB SCH] Date: **8/12/2013** Sheet **3** of **6**



Figure 13. Audio



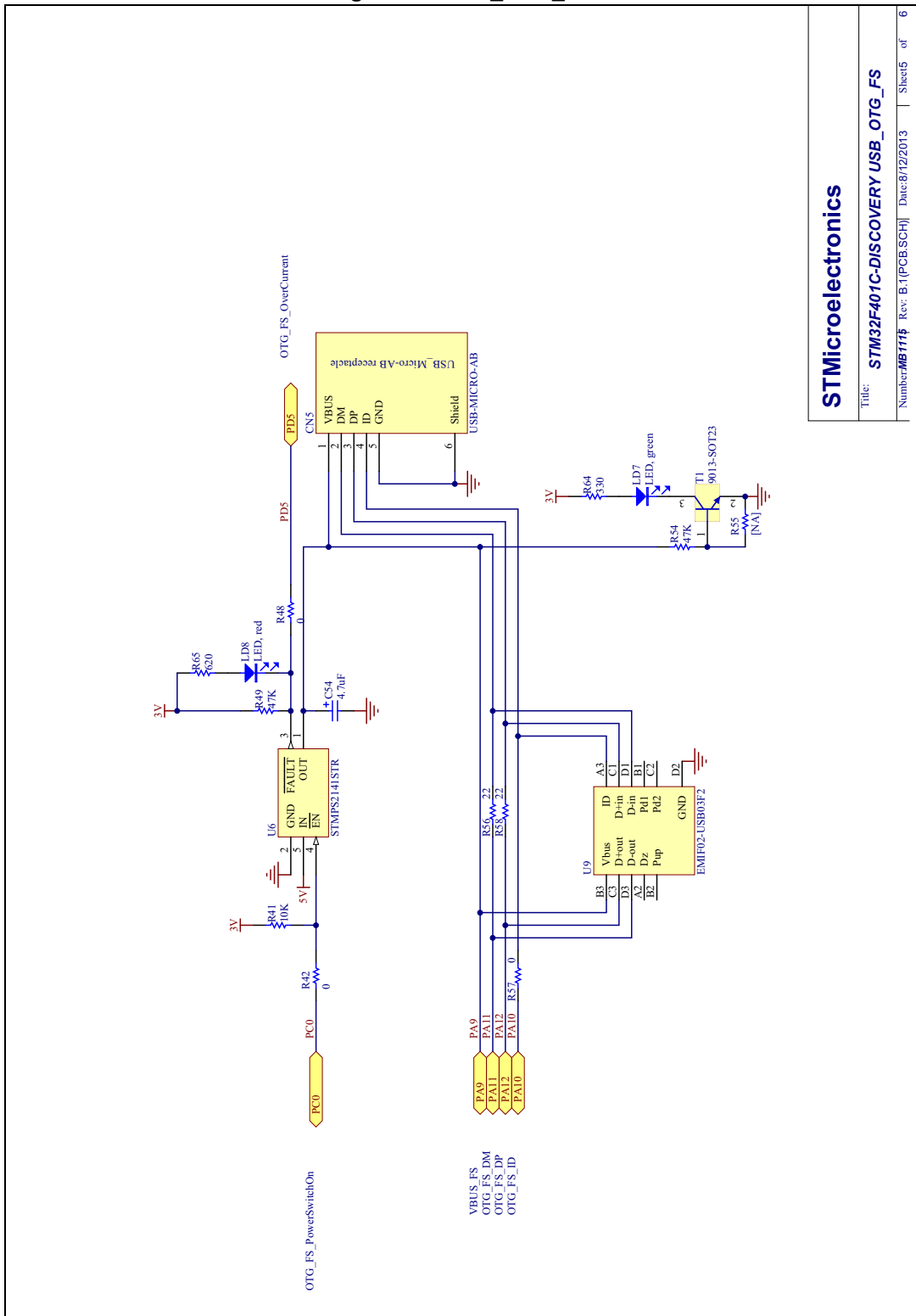
STMicroelectronics

Title: STM32F401C-DISCOVERY Audio

Number MB1114 Rev. B.1[PCB SCH] Date: 8/12/2013 Sheet 4 of 6

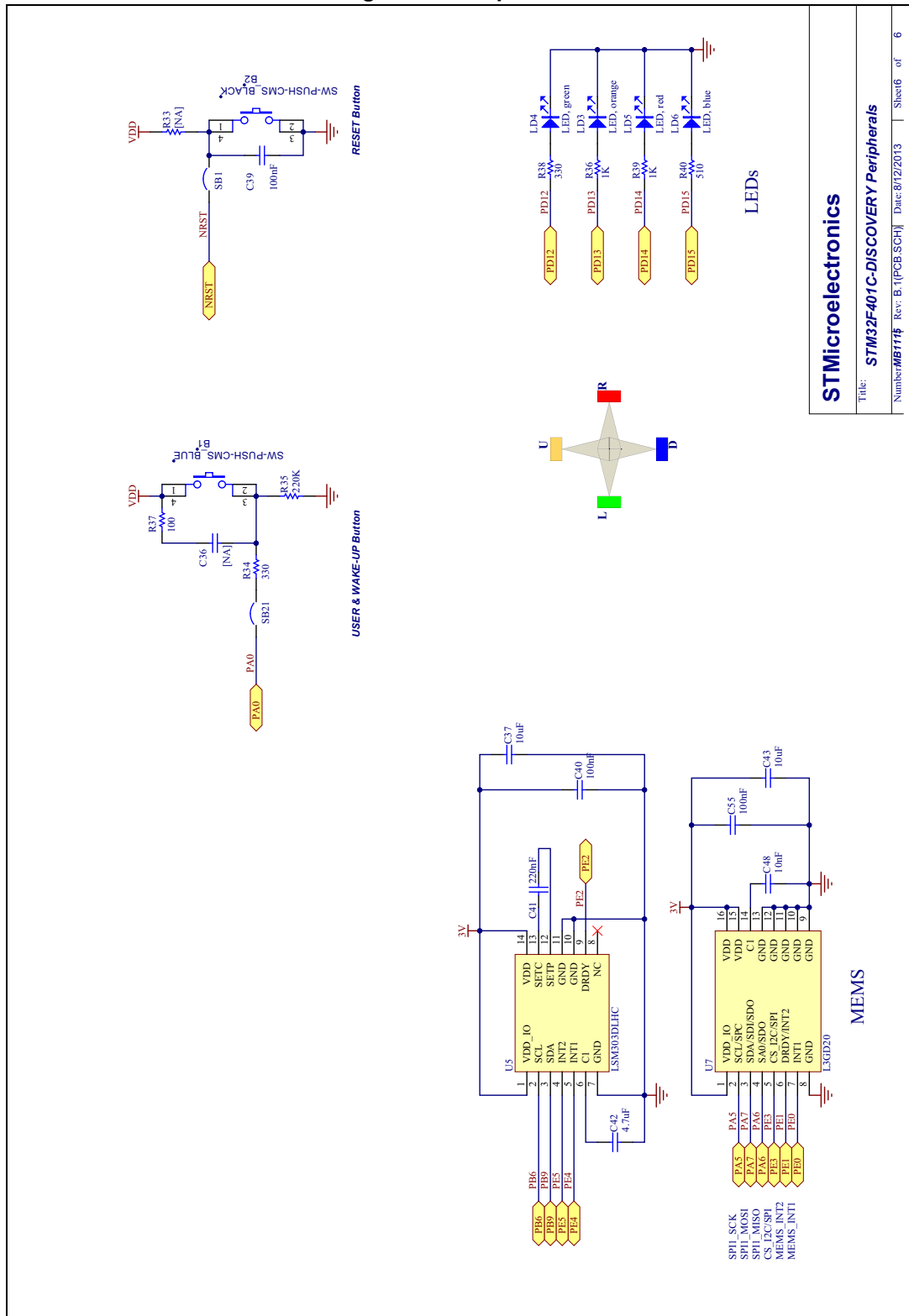


Figure 14. USB\_OTG\_FS



<b>STMicroelectronics</b>	
Title: <b>STM32F401C-DISCOVERY USB_OTG_FS</b>	
Number: <b>MB1714</b>	Rev: <b>B.1</b>   PCB[SCH]   Date: <b>8/12/2013</b>   Sheet <b>5</b> of <b>6</b>

Figure 15. Peripherals



STMicroelectronics

Title: STM32F401C-DISCOVERY Peripherals

Number: MB1717 Rev. B.1 [PCB.SCH] Date: 8/12/2013 Sheet 6 of 6



## 7 Revision history

Table 7. Document revision history

Date	Revision	Changes
10-Sep-2013	1	Initial release.

**Please Read Carefully:**

Information in this document is provided solely in connection with ST products. STMicroelectronics NV and its subsidiaries ("ST") reserve the right to make changes, corrections, modifications or improvements, to this document, and the products and services described herein at any time, without notice.

All ST products are sold pursuant to ST's terms and conditions of sale.

Purchasers are solely responsible for the choice, selection and use of the ST products and services described herein, and ST assumes no liability whatsoever relating to the choice, selection or use of the ST products and services described herein.

No license, express or implied, by estoppel or otherwise, to any intellectual property rights is granted under this document. If any part of this document refers to any third party products or services it shall not be deemed a license grant by ST for the use of such third party products or services, or any intellectual property contained therein or considered as a warranty covering the use in any manner whatsoever of such third party products or services or any intellectual property contained therein.

**UNLESS OTHERWISE SET FORTH IN ST'S TERMS AND CONDITIONS OF SALE ST DISCLAIMS ANY EXPRESS OR IMPLIED WARRANTY WITH RESPECT TO THE USE AND/OR SALE OF ST PRODUCTS INCLUDING WITHOUT LIMITATION IMPLIED WARRANTIES OF MERCHANTABILITY, FITNESS FOR A PARTICULAR PURPOSE (AND THEIR EQUIVALENTS UNDER THE LAWS OF ANY JURISDICTION), OR INFRINGEMENT OF ANY PATENT, COPYRIGHT OR OTHER INTELLECTUAL PROPERTY RIGHT.**

**ST PRODUCTS ARE NOT AUTHORIZED FOR USE IN WEAPONS. NOR ARE ST PRODUCTS DESIGNED OR AUTHORIZED FOR USE IN: (A) SAFETY CRITICAL APPLICATIONS SUCH AS LIFE SUPPORTING, ACTIVE IMPLANTED DEVICES OR SYSTEMS WITH PRODUCT FUNCTIONAL SAFETY REQUIREMENTS; (B) AERONAUTIC APPLICATIONS; (C) AUTOMOTIVE APPLICATIONS OR ENVIRONMENTS, AND/OR (D) AEROSPACE APPLICATIONS OR ENVIRONMENTS. WHERE ST PRODUCTS ARE NOT DESIGNED FOR SUCH USE, THE PURCHASER SHALL USE PRODUCTS AT PURCHASER'S SOLE RISK, EVEN IF ST HAS BEEN INFORMED IN WRITING OF SUCH USAGE, UNLESS A PRODUCT IS EXPRESSLY DESIGNATED BY ST AS BEING INTENDED FOR "AUTOMOTIVE, AUTOMOTIVE SAFETY OR MEDICAL" INDUSTRY DOMAINS ACCORDING TO ST PRODUCT DESIGN SPECIFICATIONS. PRODUCTS FORMALLY ESCC, QML OR JAN QUALIFIED ARE DEEMED SUITABLE FOR USE IN AEROSPACE BY THE CORRESPONDING GOVERNMENTAL AGENCY.**

Resale of ST products with provisions different from the statements and/or technical features set forth in this document shall immediately void any warranty granted by ST for the ST product or service described herein and shall not create or extend in any manner whatsoever, any liability of ST.

ST and the ST logo are trademarks or registered trademarks of ST in various countries.

Information in this document supersedes and replaces all information previously supplied.

The ST logo is a registered trademark of STMicroelectronics. All other names are the property of their respective owners.

© 2013 STMicroelectronics - All rights reserved

STMicroelectronics group of companies

Australia - Belgium - Brazil - Canada - China - Czech Republic - Finland - France - Germany - Hong Kong - India - Israel - Italy - Japan - Malaysia - Malta - Morocco - Philippines - Singapore - Spain - Sweden - Switzerland - United Kingdom - United States of America

[www.st.com](http://www.st.com)